

DIMENSIES VAN DE FLENZEN TYPE 1882

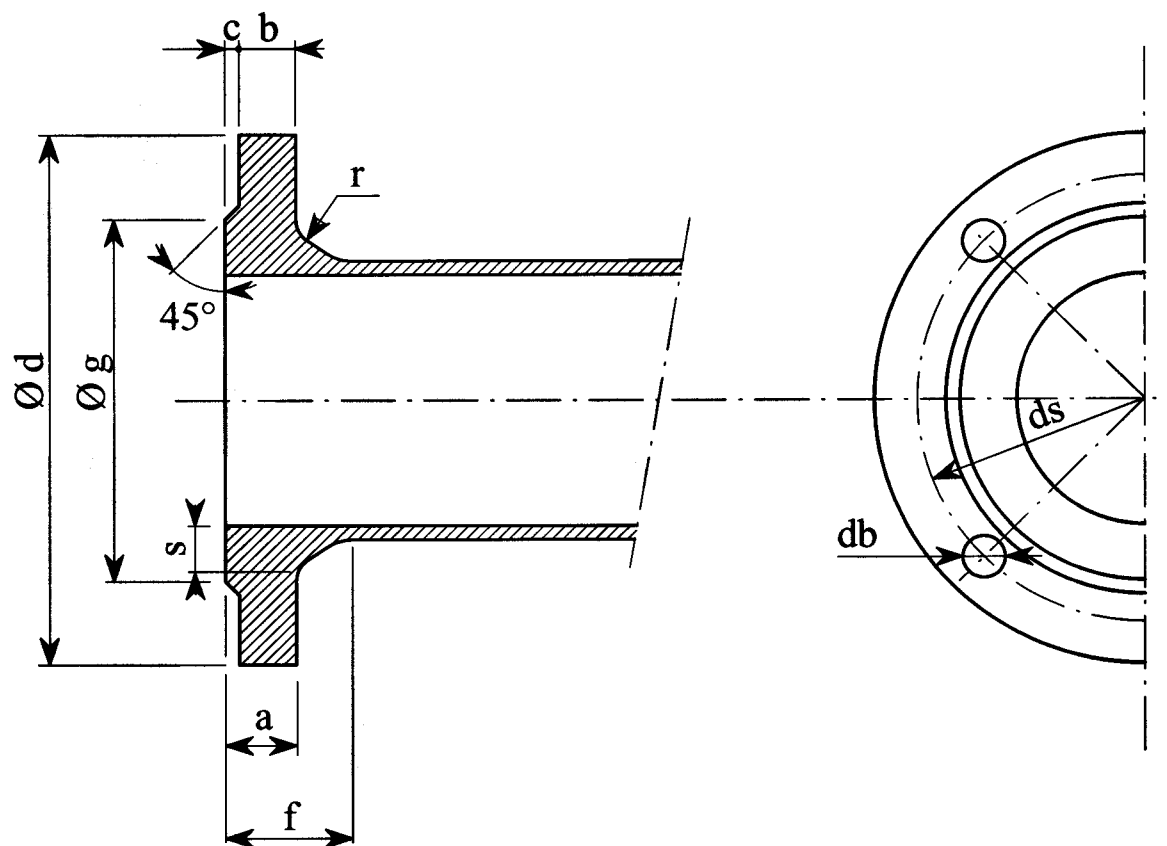

Maten in mm

Nominale middellijn (ND)	g	a	b	c	f	s	r	d	ds	Gaten		Bouten	
										Aantal	Middell. db	Middellijn mm	inches
40 (O)	90	21	18	3	39	12	5	150/90	110	2	15	12	1/2
40 (R)	90	21	18	3	39	12	5	140	110	4	15	12	1/2
50	100	21	18	3	—	—	—	160	125	4	18	16	5/8
60	110	22	19	3	41	12,5	5	175	135	4	18	16	5/8
80	130	23	20	3	43	13	6	200	160	4	18	16	5/8
100	156	23	20	3	45	13,5	6	230	180	4	22	20	3/4
125	181	24	21	3	47,5	14,5	6	260	210	4	22	20	3/4
150	206	25	22	3	50	15	6	290	240	6	22	20	3/4
(175)	235	25	22	3	—	—	—	320	270	6	22	20	3/4
200	260	26	23	3	55	16,5	8	350	300	6	22	20	3/4
(225)	285	26	23	3	—	—	—	370	320	6	22	20	3/4
250	310	27	24	3	60	18	8	400	350	8	22	20	3/4
300	360	28	25	3	65	19,5	8	450	400	8	22	20	3/4
350	420	30	26	4	70	21	8	520	465	10	26	22	7/8
400	470	31	27	4	75	22,5	10	575	520	10	26	22	7/8
450	520	32	28	4	—	—	—	630	570	12	25	22,5	7/8
500	580	34	30	4	85	25,5	10	680	625	12	26	22	7/8
550	630	38	33	5	—	—	—	740	679	14	28,5	26	1
600	680	38	33	5	95	28,5	10	790	725	16	30	24	1
650	730	38	33	5	—	—	—	840	775	18	28,5	26	1
700	780	38	33	5	105	31,5	10	900	830	18	30	24	1
750	830	38	33	5	—	—	—	950	880	20	28,5	26	1
800	890	41	36	5	115	34,5	12	1020	940	20	33	27	1 1/8
900	990	41	36	5	125	37,5	12	1120	1040	22	33	27	1 1/8
1000	1090	43	38	5	135	40,5	12	1220	1140	24	33	27	1 1/8

(O): Ovaal
(R): Rond

Deze maten zijn niet volgens de norm NBN 22, maar uit de praktijk.